

TIBOR SPEY SERIES

CLEANING



After each use, back off the drag completely and rinse the reel thoroughly with fresh, warm water, giving special attention to the backing and the perforations in the Spool. (Do not let the reel soak). Shake the reel to remove excess water and leave in an open area (indoors)

to dry overnight. The following day, put the reel through all of its drag settings and then return to free spool for storage. Periodically, especially after extensive exposure to saltwater, the line and backing should be removed and wiped down with a wet cloth to remove salt. When the reel, line and backing are completely dry, the reel should be stored in its protective pouch.

MAINTENANCE

All reels are lubricated at the factory prior to assembly and relubrication is generally not necessary. Should you wish to disassemble your reel for cleaning and/or relubrication, insert a penny into the drag adjustment stop nut; unscrew and remove the nut. Unscrew the drag adjustment knob and remove. Turn the spool backwards (against the drag) until it moves freely. Remove the spool. (Do not unscrew the Spey end cap). Clean as necessary and reassemble. If you wish to lubricate the cork drag disc, use only a small amount of Tibor Graphite Lube.

Please note: Exceeding the recommended capacity by overfilling the spool and/or putting line on too tightly or with too much tension may damage the spool and is not covered under warranty. Please refer to the capacity chart and use the Backing Groove on the spool as your guide. Should you have any questions about backing for your reel, please contact your authorized Tibor dealer.

BASIC TIBOR SPEY CAPACITIES

*Tibor Spey 8-10:	Skagit 550 Line Windcutter Spey 8/9/10F All with 200 yds. of 20 lb. Micron
*Tibor Spey 11-15:	Windcutter Spey 9/10/11F Windcutter Spey 10/11/12F Power Spey Floating 8/9F Power Spey Floating 9/10F Power Spey Floating 10/11F All with 300 yds. of 30 lb. Micron

*Capacities shown are only a basic guide. For more spey line variations, please consult your local dealer.

CONVERSION FROM RIGHT TO LEFT HAND RETRIEVE

Tibor reels are shipped from the factory with right hand retrieve unless specified. An authorized dealer can easily convert any Tibor reel from right to left hand retrieve for you. You may also convert the reel yourself by reversing the Clutch Dogs. Please refer to the numbered parts list on the reverse side.

1. Unscrew the Spey End Cap (part #27) and remove the Spey Spool (part #14).
2. Insert a penny into the Drag Adjustment Stop Nut (part #34); unscrew and remove the Nut. Unscrew the Drag Knob (part #33) and remove.
3. Remove Hub (part #18) and Main Gear (part #10) – the Gear will come off with the Hub. The Clutch Dogs (part #5) will now move freely.
4. Remove the Clutch Spring (part #11) from each Spring Retainer Block (part #7) and place it in the Retainer Block on the opposite side of the Clutch Dog.
5. Locate the Clutch Dogs so tension is created by the Clutch Spring (part #9) as the Clutch Dog is pressed against it.
6. Replace Hub and Main Gear, making sure to engage the Clutch Dogs.
7. Replace the Drag Knob and Drag Adjustment Stop Nut. Be sure to tighten the Drag Knob completely before replacing the Drag Adjustment Stop Nut.
8. Replace the Spey Spool and tighten the Spey End Cap.



TIBOR REELS

The World's Finest Fly Reels

TIBOR SPEY SERIES

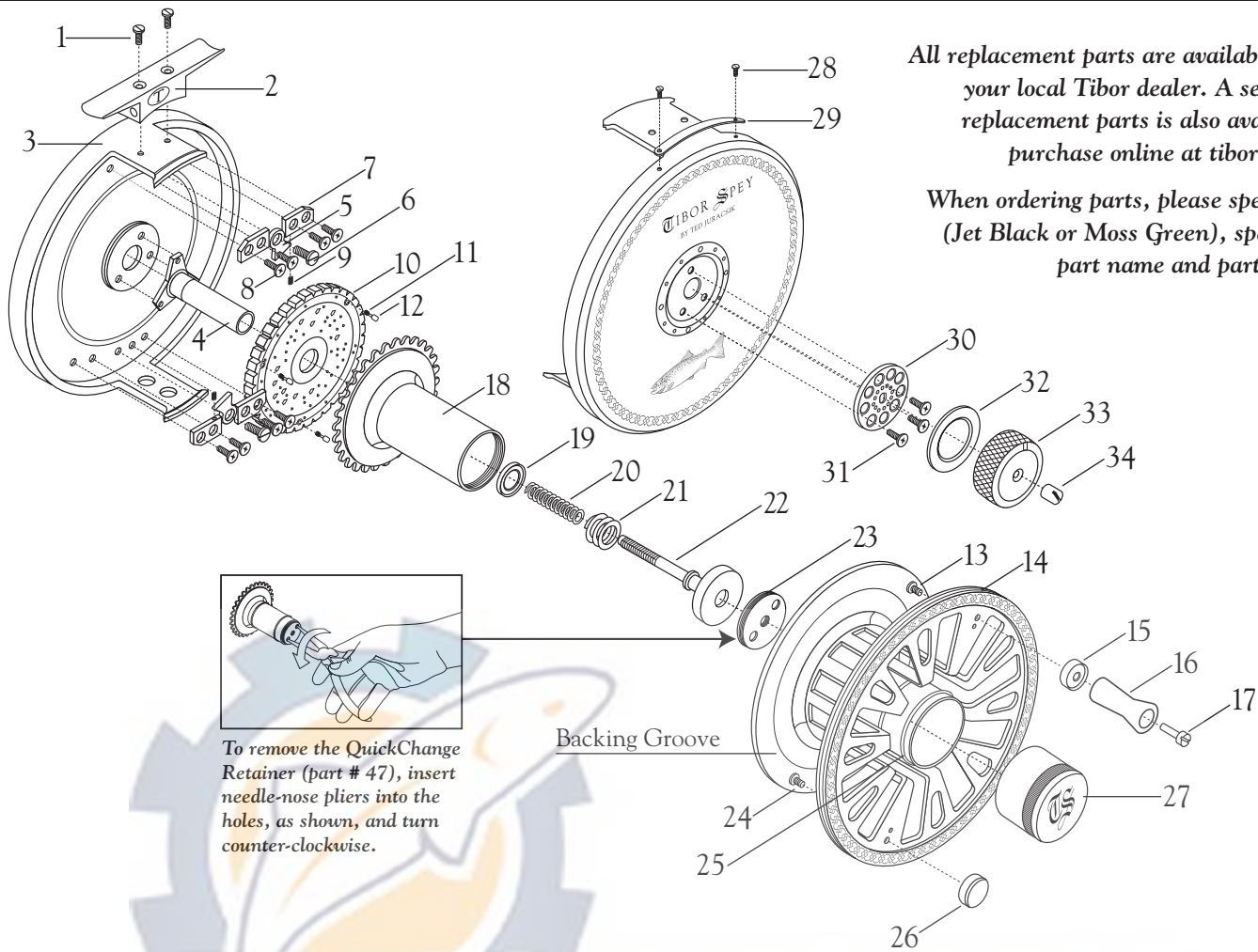

All replacement parts are available through your local Tibor dealer. A selection of replacement parts is also available for purchase online at tiborreel.com.

When ordering parts, please specify color (Jet Black or Moss Green), spey model, part name and part number.

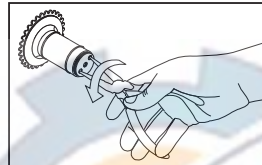

To remove the QuickChange Retainer (part # 47), insert needle-nose pliers into the holes, as shown, and turn counter-clockwise.

Ref.#	Part Name	Part#	Ref.#	Part Name	Part#
1	Reel Stand Screw	2SP	18	Hub	46SP
2	Reel Stand	4SP	19	Thrust Washer	18SP
3	Spey Frame	5SP	20	Tension Spring	3SP
4	Main Shaft	6SP	21	Main Shaft Spring	19SP
5	Clutch Dog	7SP	22	Draw Bar	20SP
6	Clutch Screw	8SP	23	Retainer Insert	47SP
7	Spring Retainer Block	9SP	24	Counterweight Screw	32SP
8	Spring Retainer Screw	10SP	25	O-Ring	45SP
9	Clutch Spring	11SP	26	Counterweight	17SP
10	Main Gear	12SP	27	Spey End Cap	21SP
11	Clicker Spring	13SP	28	Name Plate Screw	30SP
12	Clicker Pin	14SP	29	Spey Name Plate	31SP
13	Handle Screw	15SP	30	Clicker Plate	29SP
14	Spey Spool	16SP	31	Clicker Plate Screw	28SP
15	Handle Knob Seat	22SP	32	Teflon Washer	27SP
16	Handle Knob	23SP	33	Spey Drag Knob	26SP
17	Handle Knob Screw	24SP	34	Drag Adjustment Stop Nut	25SP



TIBOR REELS

The World's Finest Fly Reels

Tibor Spey Reels

Reel Stand
The balanced reel stand includes hook keepers for hiding points of large saltwater flies.

Reel Stand Screws

Hook Keeper

Dual, Positive Clutch Pawls
The drag direction is easily changed by reversing the pawl springs and pawl direction. Dual pawls provide added trophy fish drag reliability.

Ceramic Coated Main Gear
and drag pawls minimize wear for long term reliability. Main Gear and Spool rotate on 3 stainless steel ball bearings.

Clicker Pins
for outgoing signal may be easily removed for silent operation.

Large, Impregnated Cork Drag Washer
This thicker cork surface delivers superior compression and the smoothest big-game drag.

QuickChange Hub

Solid SST Draw Bar

Personalized Name Plate
Each Tibor Spey Reel features a personalized nameplate engraved free.

Frame
Our solid back frame is precision machined from the finest bar stock aluminum alloy and features the engraving of a traditional Celtic Knot pattern, Steelhead Salmon and Witness Marks.

Detented Drag Knob
features an engraved Witness Mark starting point and offers positive gripping and adjustment control.

Main Shaft Cap Screw

Backing Groove®
helps the angler to accurately determine backing capacity.

Delrin Handle*
offers positive gripping and quick release.

*Gorilla Handle & Speed Handle options also available.

Rim Control

One-Piece Large Hub Diameter Spool
The Tibor Spey Spool features it's own, unique spool design and an engraved Celtic Knot pattern that matches the frame. Our open-hubbed perforated design allow the reel to remain cool during scorching runs. Both the spool and main gear rotate flawlessly on three sealed precision stainless steel ball bearings.

QuickChange End Cap
Spool change involves only a single moving part – the stainless steel endcap.

Counterweight

Change Spools in 4 Easy Steps!

